

## INSTALLATION INSTRUCTIONS

### VEHICLE APPLICATION

Year: **2014 - 2017**  
Make: **Polaris**  
Model: **RZR 1000, XP4**  
Engine: **1000cc, Turbo (2016)**

### TOOLS REQUIRED

- 2.5mm, 4mm, 5mm Hex Key
- 10mm Wrench/Socket
- 5/16 Nut Driver
- Phillips Screwdriver, Flat Blade Screwdriver, Razor Blade, and Wire Cutters

### BEFORE YOU START

- Please read the entire installation manual before proceeding.
- Ensure all components listed on page 7 are present.
- If you are missing any of the components, call our customer support at (909) 947-0015.
- Do not work on the vehicle while the engine is hot.
- Make sure the engine is turned off, the vehicle is in Park and the Parking Brake is set.

### THREAD LOCKER USE

We have provided a small tube of thread locker in your kit. Whenever you see the symbol above on a step of the instructions apply 1 small drop of the thread locker to the threads of the screws or bolts. This will keep your hardware from vibrating loose during rough driving. If the hardware ever needs to be removed, do so slowly to avoid having the inserts strip out from the plastic.

### WARNING:

**THIS EQUIPMENT SHOULD BE INSTALLED, ADJUSTED, AND SERVICED BY PERSONNEL FAMILIAR WITH THE CONSTRUCTION AND OPERATION OF THIS TYPE OF EQUIPMENT AND THE HAZARDS INVOLVED. FAILURE TO OBSERVE THIS PRECAUTION COULD RESULT IN SEVERE INJURY. READ THIS MANUAL THOROUGHLY AND MAKE SURE YOU UNDERSTAND THE PROCEDURES BEFORE YOU ATTEMPT TO OPERATE THIS EQUIPMENT. THE PURPOSE OF THIS MANUAL IS TO PROVIDE YOU WITH INFORMATION NECESSARY TO SAFELY OPERATE, MAINTAIN, AND TROUBLESHOOT THIS EQUIPMENT. DO NOT USE THIS EQUIPMENT FOR ANY REASON OTHER THAN ITS INTENDED PURPOSE. FAILURE TO FOLLOW THESE INSTRUCTIONS WILL VOID ANY WARRANTY. KEEP THIS MANUAL FOR FUTURE REFERENCE. THE INFORMATION CONTAINED IN THIS MANUAL IS SUBJECT TO CHANGE WITHOUT NOTICE.**

Product will intake and expel both air and loose materials with high force and velocity.

- Install product on roll cage, so air inlet is not blocked.
- Do not place face, hair, extremities, clothing, or other loose material in front of air inlet or outlet during use.
- Install product securely to roll cage and avoid placing hair, extremities, clothing, or other loose material in front of air inlet during use.

Moving parts are sharp and could cause personal injury.

- Keep fan safety guard and exhaust cover in place while operating and after service.
- Disconnect product from power source before servicing.

Scavenge Fan is designed for use in conjunction with an UTV's operating manual, and state and federal law.

- Keep your seat belt fastened and wear a helmet while operating the vehicle.

Risk of electric shock!

- Improper installation, maintenance or operation could cause serious injury or property damage.

**SEE EXPLODED VIEW ON PAGE 7**

## INSTALLATION INSTRUCTIONS (CONTINUED)

1. Determine where on the roll cage you want to mount the Particle Separator (A). Make sure you have enough room to fit the clamps and particle separator on the roll cage without any interference. Planning ahead will save you time and frustration during the install. Our clamps are adaptable enough to work around any additional accessories you may have on the roll cage in addition to the particle separator.



2. At the mounting locations determined previously, install the Strap (O) onto the roll cage. Loosely wrapping some plastic around the roll cage will help sliding the strap onto the roll cage easier and prevent scratches.



3. Install the Pivot Body (N) onto the Strap (O) with the supplied Screw (S), Locknut (T), and Washer (D) on the roll cage. Do this for both sides. Do not fully tighten the screws and locknuts. Leave the strap loose.

4. Install the Adapter (F) on the mounting bosses of the Particle Separator (A) with the supplied Screw (P) and Washer (D). Tighten these screws. Do this for both sides.



5. When installing the L Bracket (M), make sure the ribs in the L Bracket are properly seated inside the grooves of the Adapter (F). Any misalignment will damage these parts. Do not attempt to rotate these parts once assembled. They are designed to lock into place once seated. Determine the proper angle to mount the L Bracket (M) to the Adapter (F) based on the desired location for the Particle Separator (A). Make sure the L Bracket is properly seated on the adapter before tightening it in place with the Screw (R) and Washer (Q). Do not tighten the hardware if these parts are not seated properly or damage may result. Repeat for the other side of the Particle Separator and make sure the L Bracket on both sides are pointed in the same direction and are aligned with each other.

6. Install the L Bracket (M) onto the Pivot Body (N) using Screw (R) and Washer (Q). You may have to adjust the position of the Strap (O) and pivot body to get the holes to line up. Do this for both sides. Having an extra pair of hands holding the Particle Separator (A) to help line up the holes will make the install easier.



7. Once you are satisfied with the position, tighten the Screw (S), Locknut (T), and Washer (D) at the Strap (O). Do this for both sides.

8. Go over all the screws and locknuts again to make sure they are secure and that the Particle Separator (A) is firmly attached to the roll cage.

SEE EXPLODED VIEW ON PAGE 7



## INSTALLATION INSTRUCTIONS (CONTINUED)

9. Loosen the screw at the passenger side frog skin side cover. Lift up and pull towards the front of the vehicle to remove the frog skin side cover.



10. Place a Hose Clamp #56 (G) over the stock air box inlet. Install the Duct Adapter (F) into the stock air box inlet with the larger OD facing up and tighten the hose clamp.



11. Insert one end of the Duct (E) onto the Duct Adapter (F). Bring the other end towards the plenum on the Particle Separator (A). Note the length on the duct you want to cut. We recommend cutting the duct an extra 3" longer so that the ends, along with any wire and strings, can be folded in for a cleaner look.



12. Pierce the Duct (E) using a razor, centered between the two wire reinforcements. Cut all the way around. Try to cut the duct straight around the center as close as possible.



13. Use scissors to begin the cut. Aim the scissors towards the start of the cut. Do not try to cut through the wire with scissors. Use a mini-bolt or a heavy duty wire cutter to finish cutting through the wire and strings.

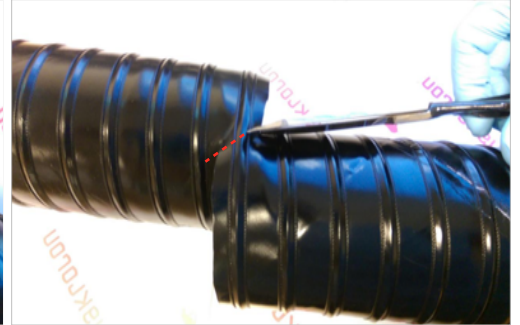

14. (Optional) Regular staples can be used to secure the ends of the strings to the duct.



15. (Optional) For a cleaner appearance, take the end of the wire and tuck it inside the duct. Do this for both ends of the duct if needed.



16. Install the Duct (E) onto the Duct Adapter (F) and tighten Hose Clamp #56 (O).



17. Insert the other end of the Duct (E) into the plenum on the Particle Separator (A). Tighten Hose Clamp #56 (O).



18. Install the Side Cover (B). Use a 4mm hex key on the Screw (C) and Washer (D) to secure the side cover to the body.

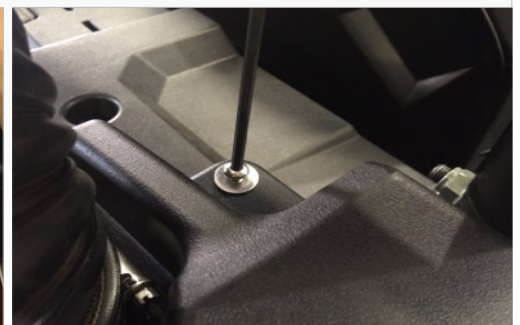

SEE EXPLODED VIEW ON PAGE 7



## INSTALLATION INSTRUCTIONS (CONTINUED)

19. Use the provided Velcro Strap (H) to secure the Duct (E) to the roll cage.



20. Familiarize yourself with the Wire Harness (J) and each of the connectors. Coming from the relay should be a pig tail, fan connector and ring terminals. Pig Tail Wire is used in conjunction with the Posi-Tap (U) to tap into a power source. Ring Terminals has the fuse holder with the red and black ring terminals for the battery. Fan Connector has the connector to power the Particle Separator (A).

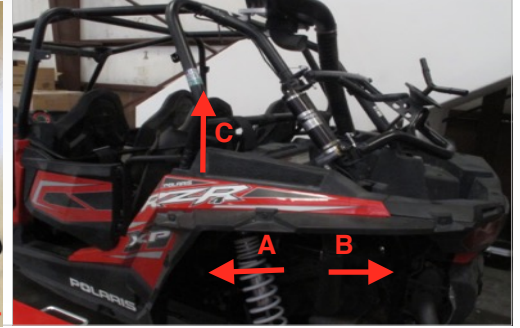
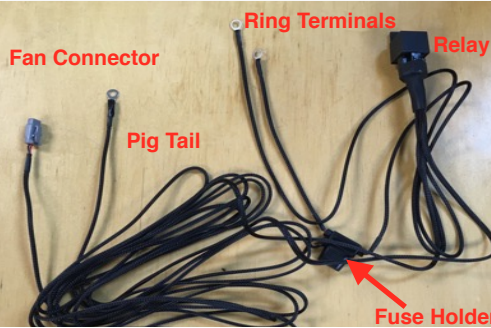

21. Remove the rear driver's side seat by pulling the latch under the seat and lifting up to reveal the battery compartment. If the vehicle is a two-seater, remove the driver's seat.



22. Remove the nut from the negative battery terminal clamp and disconnect the terminal from the battery. Then, remove the nut from the positive battery terminal clamp. Install the ring terminals onto the battery terminal clamps. Red wire with the fuse holder to (+) and Black wire to (-) and reinstall the nuts. Secure the positive terminal first and then secure the negative terminal.



23. Feed the fan connector and pig tail through the gap behind the rear driver's side fender. This gap comes out from the battery compartment.

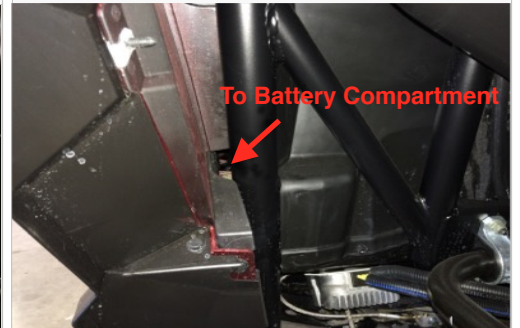

24. The Pig Tail wire comes with a ring terminal that could be connected to a powered terminal bus bar. The layout shown in this instruction manual serves as a guide for an acceptable location to route the wire harness for those without a powered bus bar. Route the wire along the frame and hoses toward the tail light assembly. Route the harness so that the wires will not get damaged from heat, the environment or pinched while the UTV is operating.

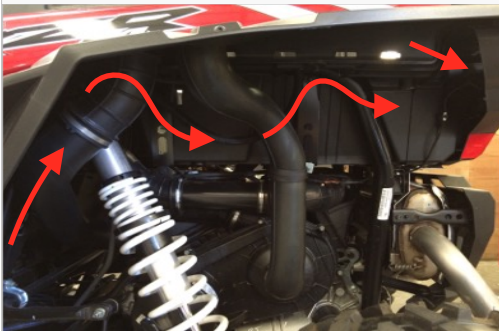

25. Disconnect the connector on the driver side taillight assembly. If necessary use a flat head screwdriver to spread out tab slightly so you can pull the connector out.

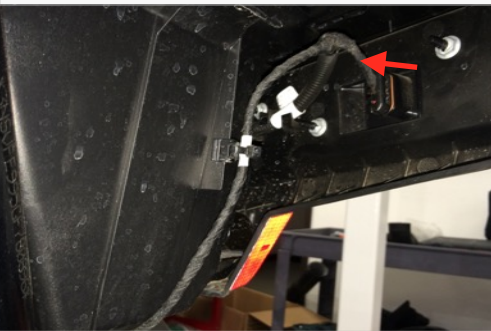

26. Find the Taillight Adapter (K) provided. This will be used to tap into the wire harness assembly connector.

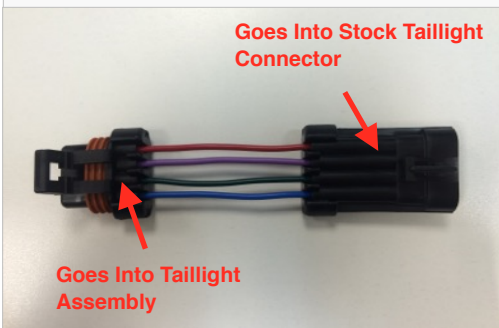

27. Use the supplied Posi-Tap (U) and unscrew the large top cap. Place the cap in between the red wire on the Taillight Adapter (K). This will be your power source.

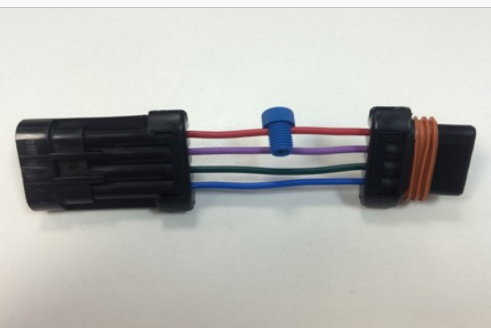

28. Screw the body around the cap until it is firmly tight.

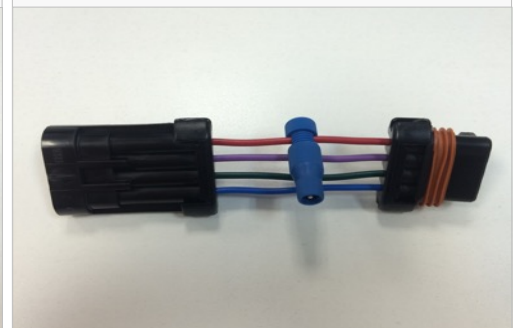

SEE EXPLODED VIEW ON PAGE 7

## INSTALLATION INSTRUCTIONS (CONTINUED)

29. Cut off the terminal and strip about 3/8" of insulation off the pig tail wire. Unscrew the bottom cap on the Posi-Tap (U) and insert the pig tail wire through it.



30. Insert the pig tail wire into the Posi-Tap, making sure the strands go around the metal core. While holding the wire in place, screw the bottom cap back on until it is firmly tight. Double check both caps to make sure they are tight.



31. Connect the Taillight Adapter (K) into the taillight assembly and then into the stock taillight connector. Use Cable Ties (I) effectively to secure the harness away from any exhaust components or moving parts that could potentially damage the harness.



32. Route the fan connector up the roll cage and connect it into the Particle Separator (A). Note the color of the wires whenever connecting or disconnecting this connector. Make sure not to cross the connectors. Power to power and ground (black) to ground (black). The connector should snap into each other with very little resistance. Do not try to force the connectors into each other.



33. Use the Cable Ties (I) or Velcro (H) provided to secure the wire to the roll cage.



34. Group together any excess wires and Cable Tie (I) them together. Use another cable tie and secure the bundle in places away from any exhaust components or moving parts that could potentially damage the harness.

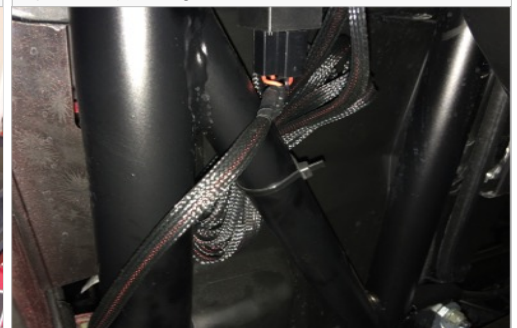

35. Reinstall the seat. Look for the two seat tabs at the base of the seat. Slide the tab through metal rail first and then push the seat down. You should hear a click when the adapter on the bottom of the seat snaps into the seat adapter.

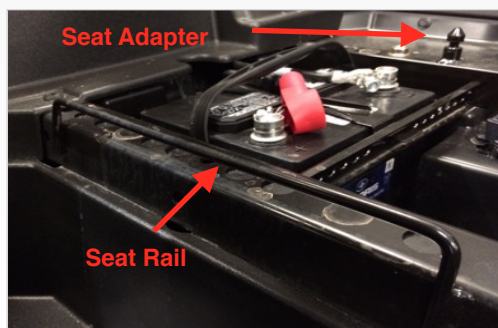
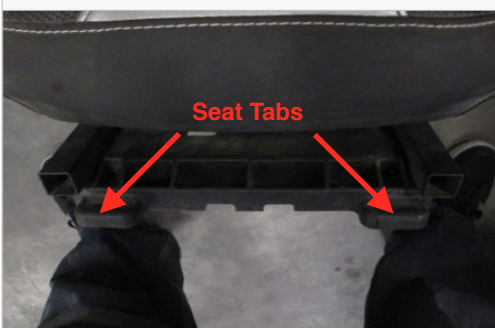

36. Make sure the connectors are all plugged in and secure. Turn the ignition on and make sure air is blowing out the exhaust. If air is not blowing out, double check your electrical connections. When you turn the ignition off, the fan will stay on for several seconds, and is normal. Your installation is now complete.



SEE EXPLODED VIEW ON PAGE 7

## INSTALLATION INSTRUCTIONS (CONTINUED)

### RELATED ITEMS FOR YOUR PURCHASE



Stainless Steel Faceplate  
(Brushed)  
SKU# 76-3000



Stainless Steel Faceplate  
(Polished)  
SKU# 76-3001



Stainless Steel Faceplate  
(Havasu Red)  
SKU# 76-3002



Stainless Steel Faceplate  
(Voodoo Blue)  
SKU# 76-3003

Order online today at [www.sbfilters.com](http://www.sbfilters.com) or through your local S&B distributor.

### SIDE NOTE

S&B recommends that you apply a layer of waterproof grease, such as made by Bel-Ray or Super Lube, on the inside flange of the stock air filter to keep dust from bypassing the seal.

### ONGOING MAINTENANCE

Your Particle Separator requires very little if any maintenance depending on where you drive; however, you should check to make sure that none of the openings on front of the Particle Separators are blocked by mud or other debris each time you exit the UTV. You should also make sure the scavenge fan is operating properly. To do so, simply check to make sure the fan is still blowing out air (for about 15-20 seconds) when you turn off your UTV as this is a normal condition. If the fan is not blowing out air or the airflow seems lower than when you initially installed your system, please contact S&B tech support. To clean your Particle Separator, review the cleaning instructions below.

SEE EXPLODED VIEW ON PAGE 7



**EXPLODED VIEW**

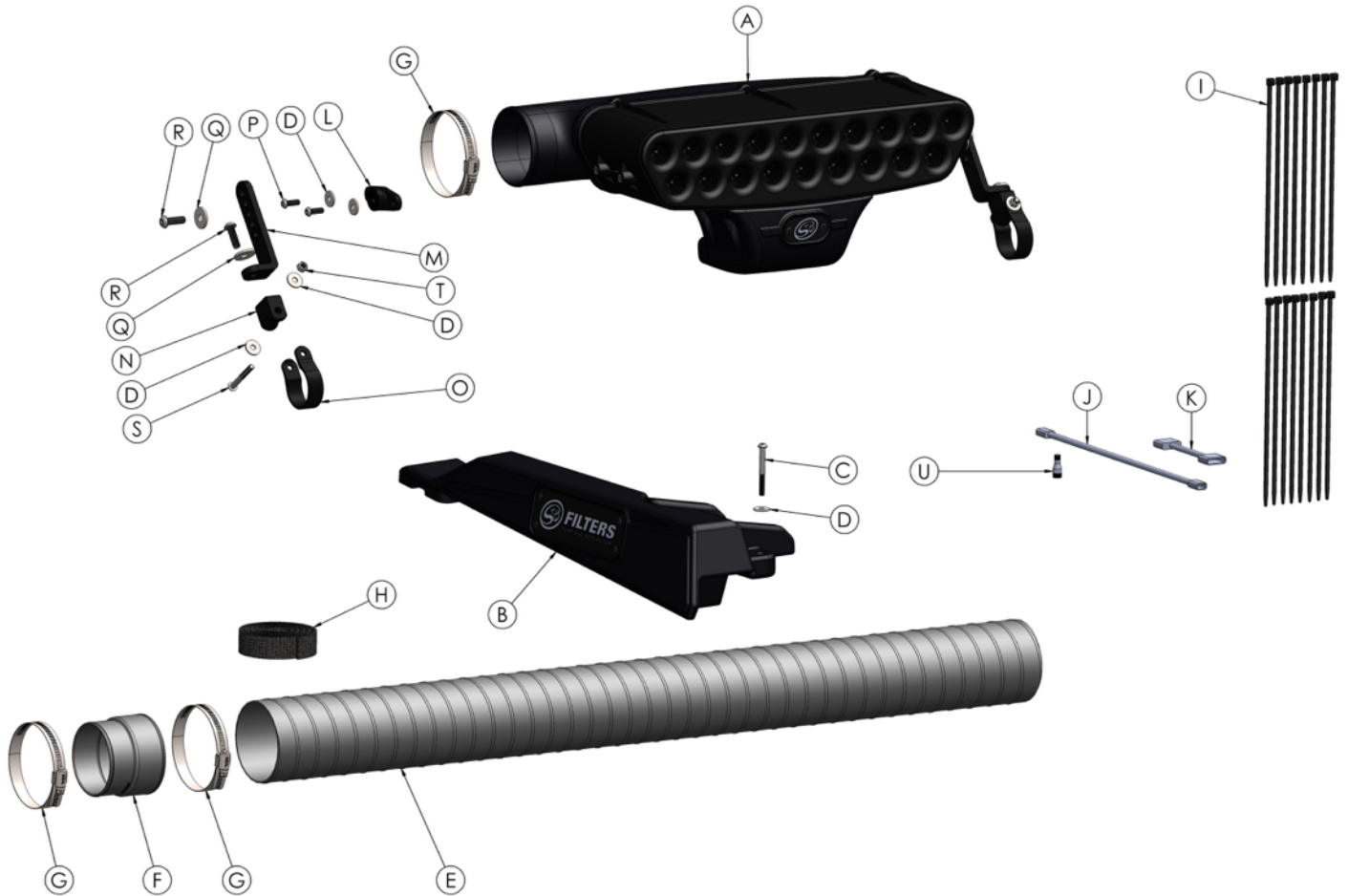

| ITEM | QTY. | DESCRIPTION                      | PART NUMBER |
|------|------|----------------------------------|-------------|
| A    | 1    | PARTICLE SEPARATOR               | AL2003-00   |
| B    | 1    | SIDE COVER                       | AL1244-01   |
| C    | 1    | SCREW, BHCS, M6 x 1mm x 55mm     | AI1754-00   |
| D    | 9    | WASHER, M6                       | AI1755-00   |
| E    | 1    | FLEXIBLE DUCT, 3.5" ID, 39" LONG | AI1735-01   |
| F    | 1    | DUCT ADAPTER                     | AI1731-00   |
| G    | 3    | HOSE CLAMP, #56                  | AG1019-00   |
| H    | 1    | VELCRO STRAP, 36" LONG           | AI1779-01   |
| I    | 16   | CABLE TIE, 9" LONG               | AI1750-00   |
| J    | 1    | WIRE HARNESS                     | AI1796-00   |
| K    | 1    | TAILLIGHT ADAPTER HARNESS        | AI1798-00   |
| L    | 2    | ADAPTER, CLAMP                   | AI1800-00   |

| ITEM | QTY. | DESCRIPTION                     | PART NUMBER |
|------|------|---------------------------------|-------------|
| M    | 2    | L-BRACKET, CLAMP                | AI1781-00   |
| N    | 2    | PIVOT BODY, CLAMP               | AI1782-00   |
| O    | 2    | STRAP, CLAMP                    | AI1783-00   |
| P    | 4    | SCREW, BHCS, M6 x 1mm x 18mm    | AI1802-00   |
| Q    | 4    | WASHER, M8                      | AI1742-00   |
| R    | 4    | SCREW, BHCS, M8 x 1.25mm x 25mm | AI1788-00   |
| S    | 2    | SCREW, BHCS, M6 x 1mm x 50mm    | AI1801-00   |
| T    | 2    | LOCKNUT, M6 NYLON INSERT        | AI1790-00   |
| U    | 1    | POSI-TAP                        | AI1799-00   |
|      |      |                                 |             |
|      |      |                                 |             |